

REV.	DATE	REVISION DESCRIPTION	PCN NO.
A	NOV.7/00	TANK DRAIN MOVED TO SIDE	

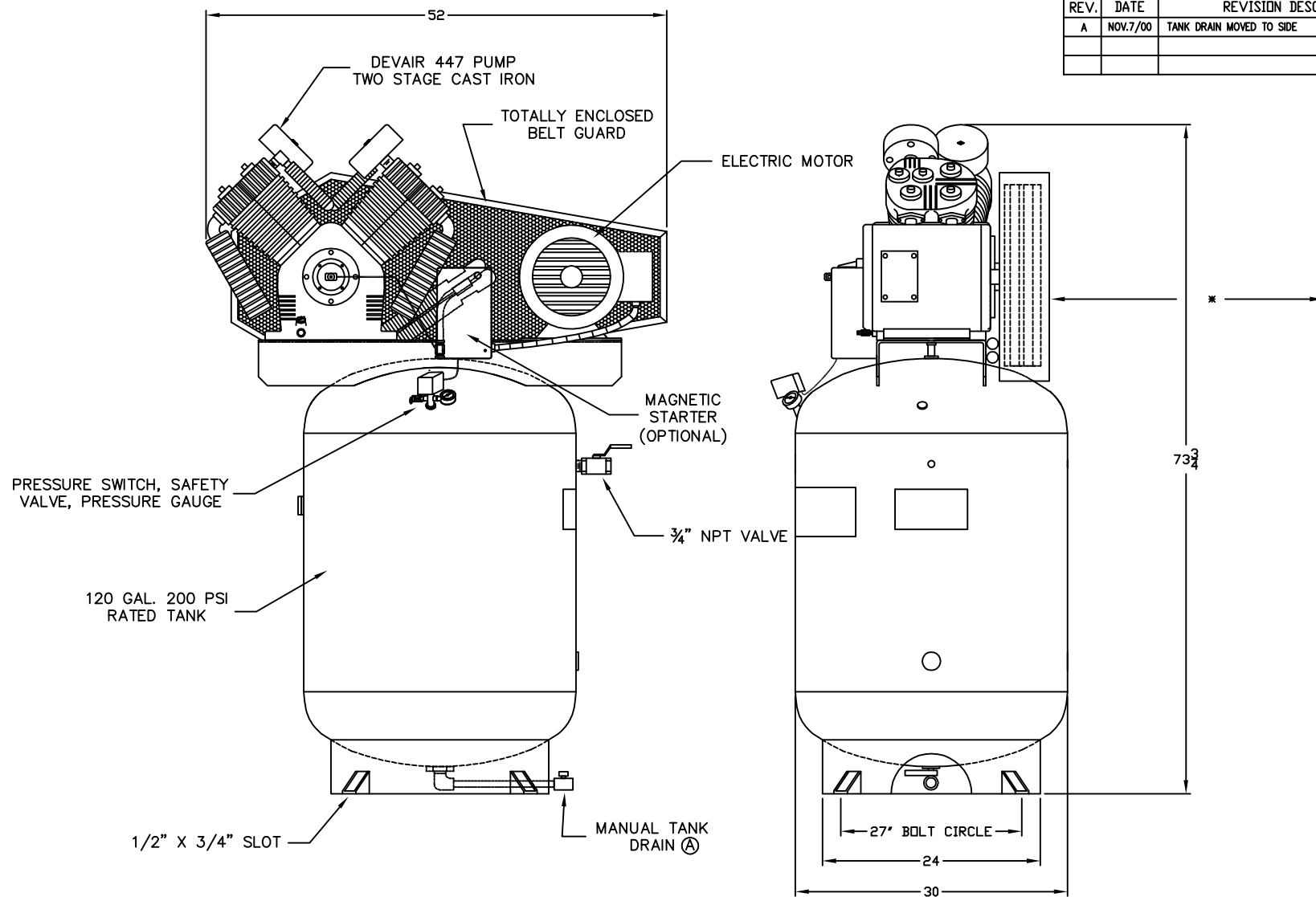

COMPRESSOR OUTFIT DATA				PRESSURE SETTING		RECEIVER CAPACITY		COMPRESSOR PUMP DATA				WEIGHT		ELECTRICAL				
MODEL	HP	DISP SCFM	DEL'Y SCFM	PSIG	KPA	GAL.	LITRS	TYPE	CYLD.	STAGE	RPM	LB.	KG.	VOLTAGE	200/3	230/3	460/3	575/3
VATV-5063	10	43.3	36.8	150	1034	120	454	447	4	2	590	900	408	F.L.A.	31	28	14	11

\* 18" MINIMUM CLEARANCE FOR PROPER AIR FLOW ACROSS COMPRESSOR.

IMPORTANT NOTE: THIS PRINT IS THE CONFIDENTIAL PROPERTY OF DV SYSTEMS, INC. IT IS NOT TO BE USED OR REPRODUCED IN ANY MANNER, NOR SUBMITTED TO OTHER PARTIES FOR EXAMINATION WITHOUT THE PRIOR APPROVAL OF DV SYSTEMS, INC. DV SYSTEMS, INC. IS CONTINUALLY TRYING TO IMPROVE ITS PRODUCTS. SPECIFICATIONS SUBJECT TO CHANGE WITHOUT NOTICE.

FRACTIONAL DIMENSIONS:  $\pm 1/32$   
 DECIMAL DIMENSION:  $\pm .005$   
 ANGLES:  $\pm 1'$   
 \*UNLESS OTHERWISE SPECIFIED



NAME OF PROJECT				DESCRIPTION OF DRAWING			
10 HP SIMPLEX C/W 447 PUMP				COMPRESSOR OUTFIT			
DRAWN BY		CHECKED BY		DATE		SCALE	
ADAM SMITH				SEPT. 11/00		N.T.S.	
DRAWING NO.				SHT NO		REV	
VATV-5063						A	

	PART NUMBER	DESCRIPTION
1	357-9401	FILTER ASSEMBLY
2	357-9701	FILTER ELEMENT
3	CT-9480	AFTERCOOLER TUBE
4	CT-9479	AFTERCOOLER TUBE
5	447-4523	PUMP ASSEMBLY
6	445-2-1	FLYWHEEL - 20" OD
7	EG-9487	BELT GUARD ASSEMBLY
8	MS-340-43	MAG STARTER 200/230-60-3
	MS-340-45	MAG STARTER 460-60-3
	MS-340-69	MAG STARTER 575-60-3
9	MO-6614	MOTOR 200-60-3
	MO-6635	MOTOR 230/460-60-3
	MO-6613	MOTOR 575-60-3
10	PU-9091	MOTOR PULLEY
11	BT-9032	BELTS (2)
12	SSS-9003-115150	PRESSURE SWITCH
13	GA-250	PRESSURE GAUGE
14	TIA-5200	SAFETY VALVE 200 PSI
15	SS-2707	DRAIN COCK
16	TA-9499	TANK - 120 GAL VERT
17	VA-9705	BALL VALVE
18	CCV-9408	CHECK VALVE
19	CT-9487	CHECK VALVE TUBE

REV.	DATE	REVISION DESCRIPTION	PCN NO.
A	11.07.00	TANK DRAIN MOVED TO SIDE	----
B	08.22.01	EG-9487 WAS EG-9402-1-P	01-26

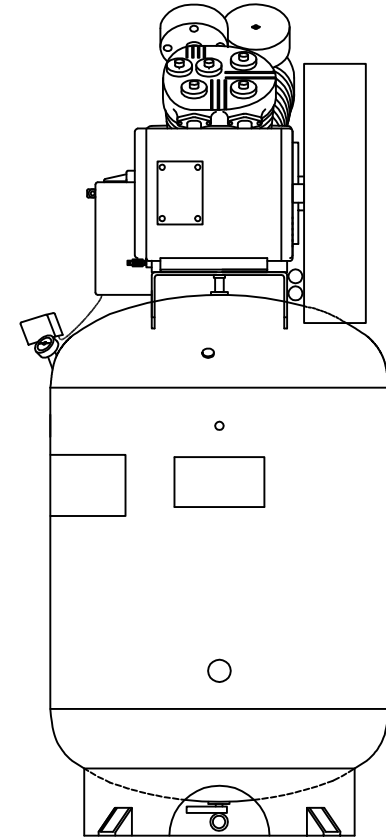
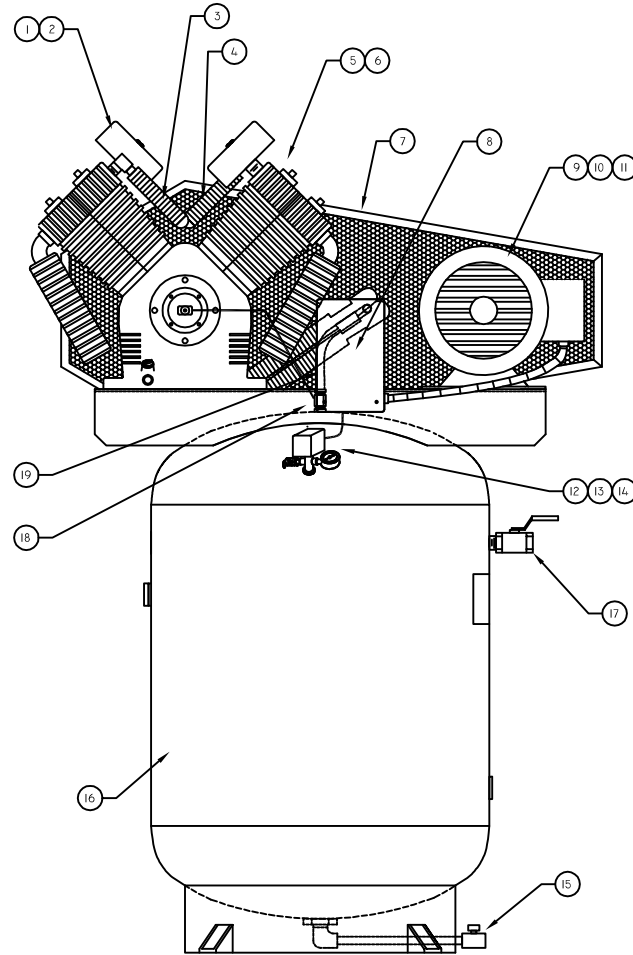

IMPORTANT NOTE: THIS PRINT IS THE CONFIDENTIAL PROPERTY OF DV SYSTEMS, INC. IT IS NOT TO BE USED OR REPRODUCED IN ANY MANNER, NOR SUBMITTED TO OTHER PARTIES FOR EXAMINATION WITHOUT THE PRIOR APPROVAL OF DV SYSTEMS, INC. DV SYSTEMS, INC. IS CONTINUALLY TRYING TO IMPROVE ITS PRODUCTS, SPECIFICATIONS SUBJECT TO CHANGE WITHOUT NOTICE.

FRACTIONAL DIMENSIONS:  $\pm 1/32$   
 DECIMAL DIMENSION:  $\pm .005$   
 ANGLES:  $\pm 1'$   
 \*UNLESS OTHERWISE SPECIFIED



NAME OF PROJECT				DESCRIPTION OF DRAWING		
10 HP SIMPLEX UNIT C/W 447 PUMP				COMPRESSOR OUTFIT		
DRAWN BY	CHECKED BY	DATE	SCALE	DRAWING NO.	SHT NO	REV
ADAM SMITH		11SEPT'00	N.T.S.	VATV-5063		B