

	PART NUMBER	DESCRIPTION
1	VAGE-9402	13 HP HONDA ENGINE
2	PU-9212	ENGINE PULLEY
3	BT-9031	BELTS
4	CT-9725	AFTERCOOLER TUBE
5	357-9401	FILTER ASSEMBLY
6	357-9701	FILTER ELEMENT
7	247-4502	PUMP ASSEMBLY
8	432-2-1	FLYWHEEL - 20" OD
9	EG-9479	BELT GUARD ASSEMBLY
10	VA-9411	BALL VALVE
11	TA-9418-4	TANK - 30 GAL HORIZ
12	VA-9705	BALL VALVE
13	UNL-9708	THROTTLE CONTROL CABLE
14	UNL-9707	CHECK VALVE - UNLOADER
15	GA-250	PRESSURE GAUGE
16	TIA-5200	SAFETY VALVE 200 PSI

REV.	DATE	REVISION DESCRIPTION	PCN NO.
A	10AUG.12	VA-9411 ADDED	12-10
B	12AUG.13	PU-9212 UPDATED	---

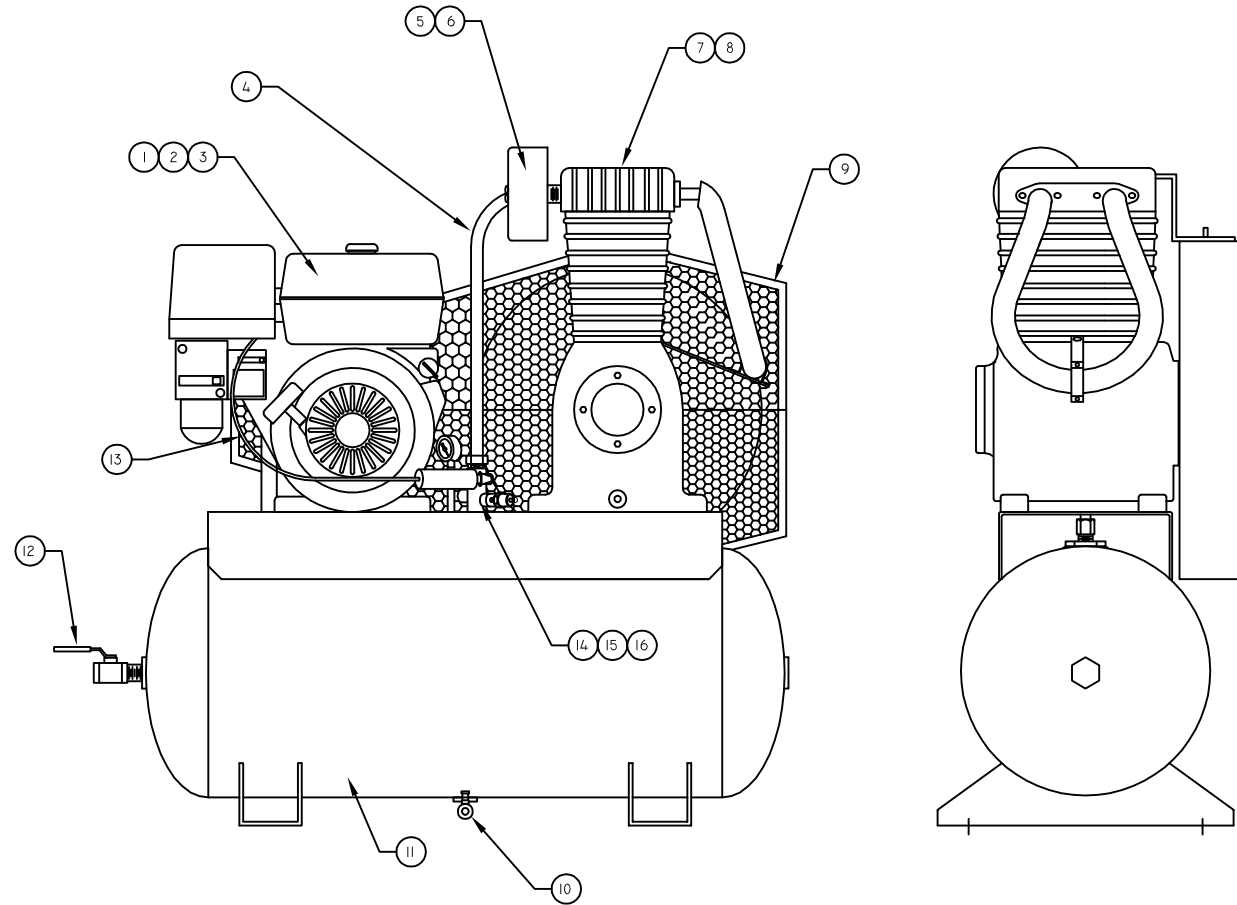

IMPORTANT NOTE: THIS PRINT IS THE CONFIDENTIAL PROPERTY OF DV SYSTEMS, INC. IT IS NOT TO BE USED OR REPRODUCED IN ANY MANNER, NOR SUBMITTED TO OTHER PARTIES FOR EXAMINATION WITHOUT THE PRIOR APPROVAL OF DV SYSTEMS, INC. DV SYSTEMS, INC. IS CONTINUALLY TRYING TO IMPROVE ITS PRODUCTS, SPECIFICATIONS SUBJECT TO CHANGE WITHOUT NOTICE.

FRACTIONAL DIMENSIONS: $\pm 1/32$
 DECIMAL DIMENSION: ± 0.005
 ANGLES: $\pm 1'$
 *UNLESS OTHERWISE SPECIFIED



NAME OF PROJECT				DESCRIPTION OF DRAWING		
13 HP SIMPLEX GAS UNIT C/W 247 PUMP				COMPRESSOR OUTFIT		
DRAWN BY	CHECKED BY	DATE	SCALE	DRAWING NO.	SHT NO	REV
IRAJ FILSOOFI		28 APR/00	N.T.S.	TASE-5030		B