

REV.	DATE	REVISION DESCRIPTION	PCN NO.
A	10\22\01	1/4" WAS 2"	01-28

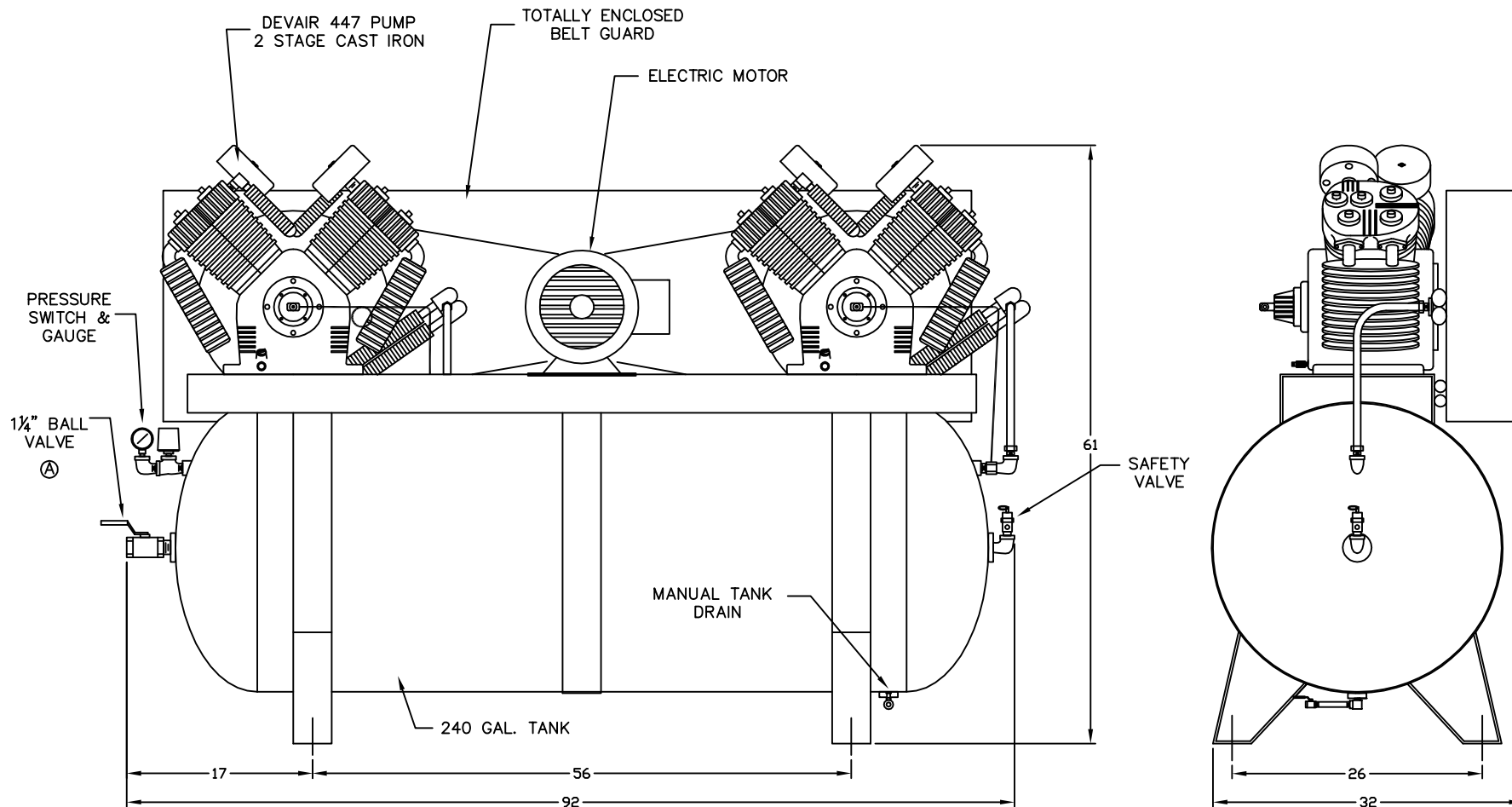

COMPRESSOR OUTFIT DATA				PRESSURE SETTING		RECEIVER CAPACITY		COMPRESSOR PUMP DATA				WEIGHT		ELECTRICAL				
MODEL	HP	DISP SCFM	DEL'Y SCFM	PSIG	KPA	GAL.	LITRS	TYPE	CYLD.	STAGE	RPM	LB.	KG.	VOLTAGE	200/3	230/3	460/3	575/3
VAX-5081	25	108.2	87.0	150	1034	240	908	447	4	2	735	2450	1111	F.L.A.	70.5	60	30	24

IMPORTANT NOTE: THIS PRINT IS THE CONFIDENTIAL PROPERTY OF DV SYSTEMS, INC. IT IS NOT TO BE USED OR REPRODUCED IN ANY MANNER, NOR SUBMITTED TO OTHER PARTIES FOR EXAMINATION WITHOUT THE PRIOR APPROVAL OF DV SYSTEMS, INC. DV SYSTEMS, INC. IS CONTINUALLY TRYING TO IMPROVE ITS PRODUCTS, SPECIFICATIONS SUBJECT TO CHANGE WITHOUT NOTICE.

FRACTIONAL DIMENSIONS:  $\pm 1/32$   
 DECIMAL DIMENSION:  $\pm .005$   
 ANGLES:  $\pm 1'$   
 \*UNLESS OTHERWISE SPECIFIED



NAME OF PROJECT				DESCRIPTION OF DRAWING			
25 HP COMPRESSOR C/W 447 PUMP				COMPRESSOR OUTFIT			
DRAWN BY		CHECKED BY		DATE		SCALE	
IRAJ FILSOOFI				18 JAN. 99		N.T.S.	
DRAWING NO.				SHT NO		REV	
VAX-5081						A	

PART NUMBER	DESCRIPTION
1 357-9401	FILTER ASSEMBLY
2 357-9701	FILTER ELEMENT
3 CT-9480	AFTERCOOLER TUBE
4 CT-9479	AFTERCOOLER TUBE
5 447-4523	PUMP ASSEMBLY
6 445-2-1	FLYWHEEL, 20" OD
7 EG-9410	BELT GUARD
8 MO-6901	MOTOR 200-60-3
MO-6903	MOTOR 230/460-60-3
MO-6991	MOTOR 575-60-3

9 PU-9210	MOTOR PULLEY
10 BT-118	BELT
11 CT-9737	CHECK VALVE TUBE
12 CCV-9408	CHECK VALVE
13 SS-00617	SAFETY VALVE
14 VA-9411	BALL VALVE
15 TA-9003-2	TANK 24.0 GAL HORIZ
16 VAX-9409	STRAP ASSEMBLY
17 VAX-9407	STRAP AND FOOT ASSEMBLY
18 VA-9722	BALL VALVE
19 GA-250	PRESSURE GAUGE

20 SSS-9003-115150	PRESSURE SWITCH
21 CT-9738	CHECK VALVE TUBE
22 VAX-9408	COMPRESSOR BASE

REV.	DATE	REVISION DESCRIPTION	PCN NO.
B	12.07.00	CHG'D TO 1" CHK VALVE & TUBE, WAS 3/4"	00-26
C	10.22.01	1 1/4" BALL VALVE WAS 2"	01-28
D	7.09.12	1/4" BALL VALVE ADDED	12-10

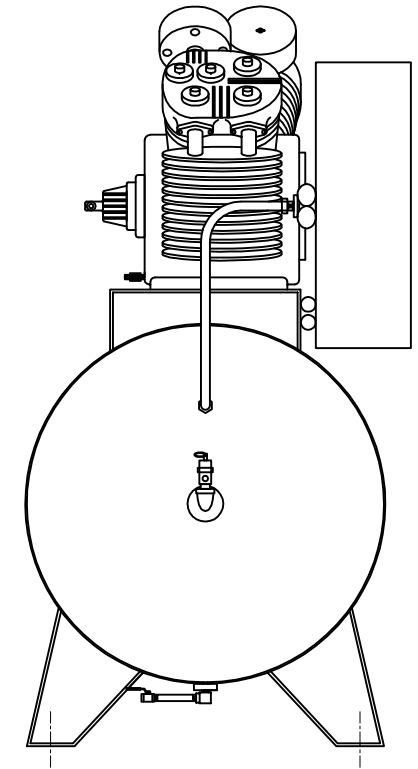
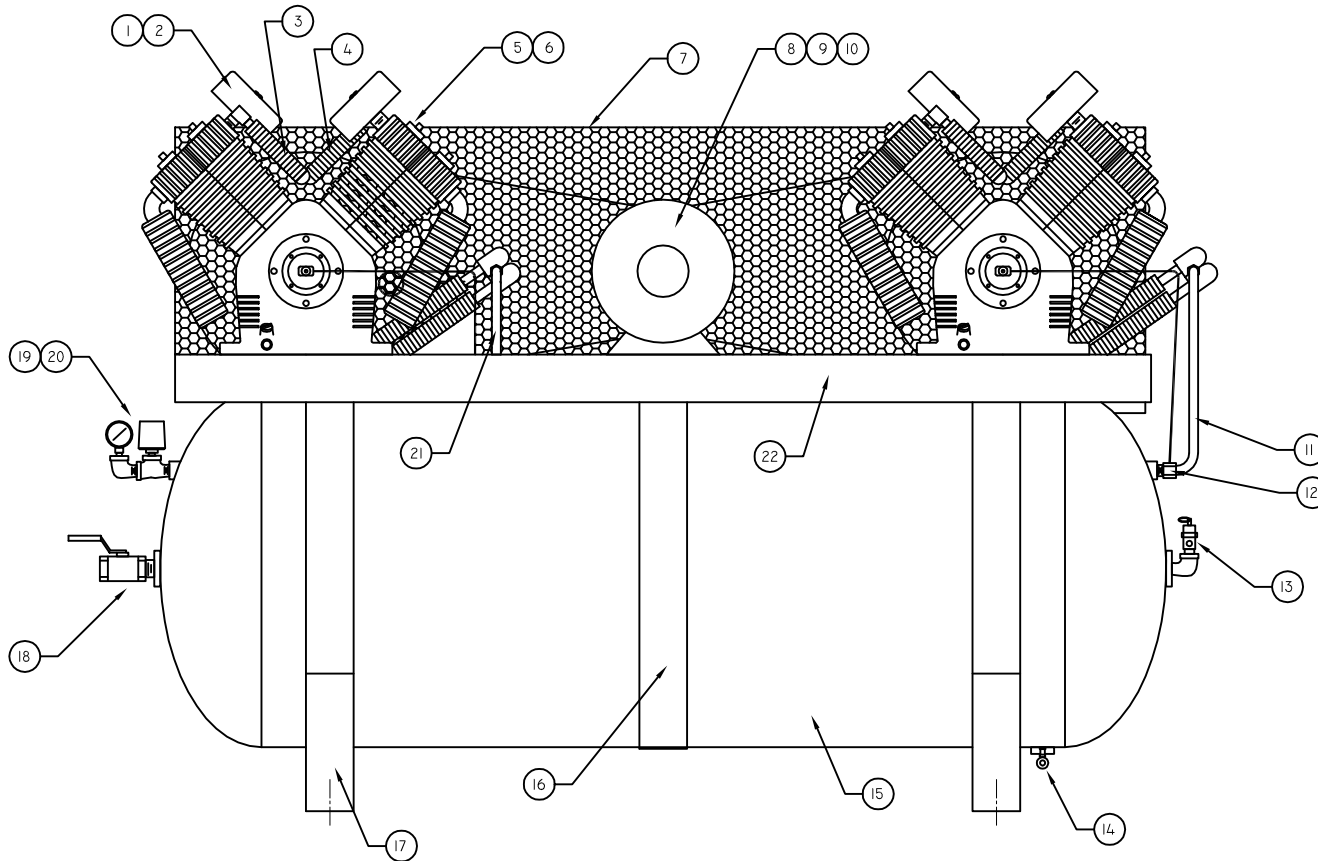

IMPORTANT NOTE: THIS PRINT IS THE CONFIDENTIAL PROPERTY OF DV SYSTEMS, INC. IT IS NOT TO BE USED OR REPRODUCED IN ANY MANNER, NOR SUBMITTED TO OTHER PARTIES FOR EXAMINATION WITHOUT THE PRIOR APPROVAL OF DV SYSTEMS, INC. DV SYSTEMS, INC. IS CONTINUALLY TRYING TO IMPROVE ITS PRODUCTS, SPECIFICATIONS SUBJECT TO CHANGE WITHOUT NOTICE.

FRACTIONAL DIMENSIONS:  $\pm 1/32$   
 DECIMAL DIMENSION:  $\pm .005$   
 ANGLES:  $\pm 1'$   
 \*UNLESS OTHERWISE SPECIFIED



NAME OF PROJECT				DESCRIPTION OF DRAWING		
25 HP UNIT C/W 447 PUMPS				COMPRESSOR OUTFIT		
DRAWN BY	CHECKED BY	DATE	SCALE	DRAWING NO.	SHT NO	REV
IRAJ FILSOOFI		28APR'00	N.T.S.	VAX-5081		D