

REV.	DATE	REVISION DESCRIPTION	ECN NO.
B	17/11/14	CAST INTERCOOLER, BELT GUARD	----
C	23/12/14	MOTOR SPECS CHANGED	---
D	30/09/16	110V NOTE ADDED	----
E	20/06/18	ELECTRICAL UPDATED	---
FA	27/09/24	ERP FLA - 31 WAS ERP FLA -36	1523174

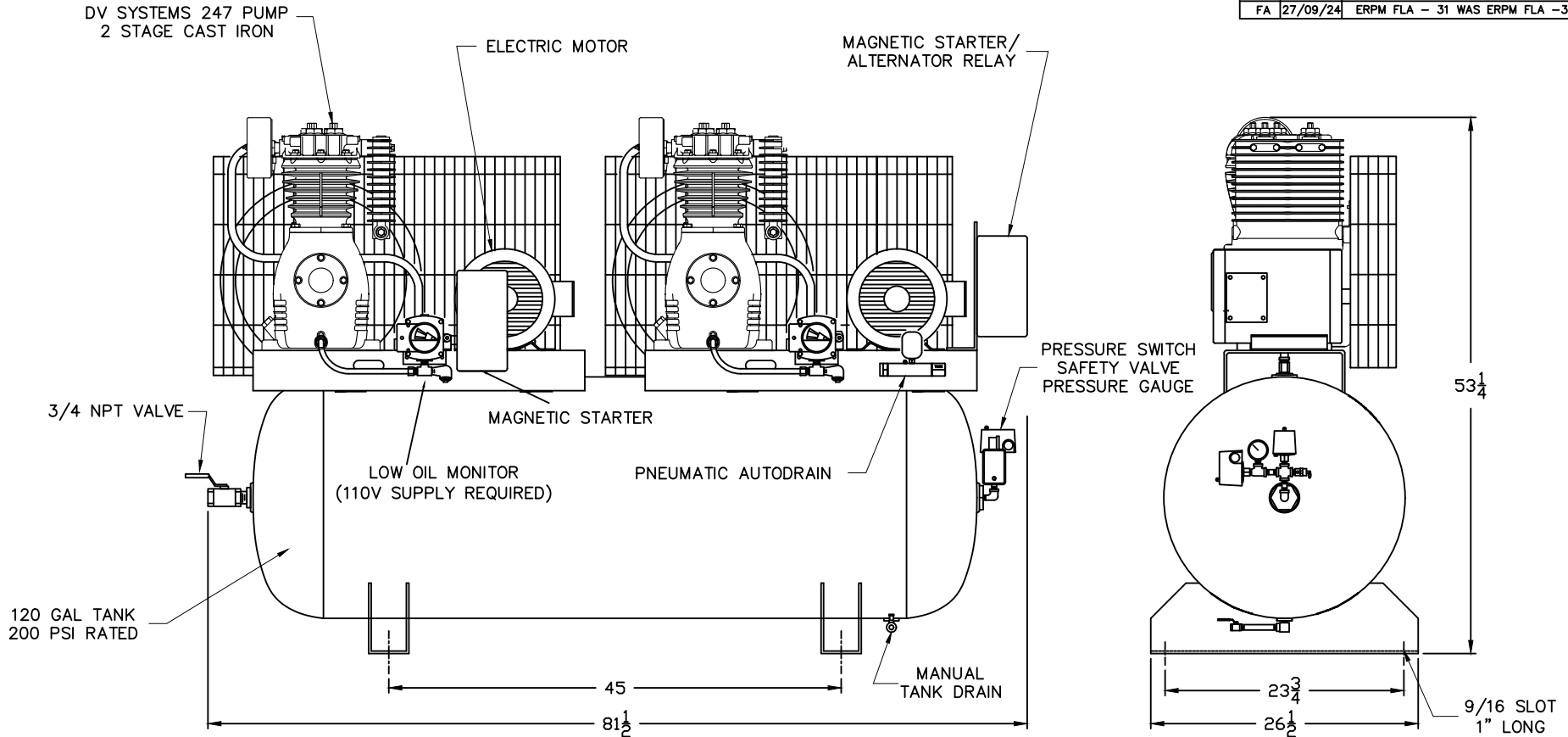

NOTE: THE COMPRESSOR SHOWN IS AN 'XL' MODEL, THIS PACKAGE INCLUDING THE (2) MOUNTED MAGNETIC STARTERS, ALTERNATOR RELAY, (2) OIL MONITORS, AND (1) PNEUMATIC AUTODRAIN.

COMPRESSOR OUTFIT DATA				PRESSURE SETTING		RECEIVER CAPACITY		COMPRESSOR PUMP DATA				WEIGHT		ELECTRICAL RATING PER MOTOR					
MODEL	HP	DISPL. SCFM	DEL'Y SCFM	PSIG	KPA	GAL.	LITRS	TYPE	CYLD.	STAGE	RPM	LB.	KG.	VOLTAGE	230/1	200/3	230/3	460/3	575/3
TAS-5562-XL	7.5	2 X 28.9	2 X 25.9	150	1034	120	454	247	2	2	800	1103	500	F.L.A.	31.0	23.3	19.4	9.7	8

IMPORTANT NOTE: THIS PRINT IS THE CONFIDENTIAL PROPERTY OF DV SYSTEMS, INC. IT IS NOT TO BE USED OR REPRODUCED IN ANY MANNER, NOR SUBMITTED TO OTHER PARTIES FOR EXAMINATION WITHOUT THE PRIOR APPROVAL OF DV SYSTEMS, INC. DV SYSTEMS, INC. IS CONTINUALLY TRYING TO IMPROVE ITS PRODUCTS, SPECIFICATIONS SUBJECT TO CHANGE WITHOUT NOTICE.

FRACTIONAL DIMENSIONS: $\pm 1/32$
 DECIMAL DIMENSION: $\pm .005$
 ANGLES: $\pm 1'$
 *UNLESS OTHERWISE SPECIFIED



NAME OF PROJECT				DESCRIPTION OF DRAWING	
HDI PISTON COMPRESSOR				7.5 HP XL COMPRESSOR OUTFIT	
DRAWN BY		CHECKED BY	DATE	SCALE	DRAWING NO.
A SMITH			23DEC'14	N.T.S.	TAS-5562-XL
					SHT NO
					REV
					FA

PART NUMBER	DESCRIPTION
1 357-9401	FILTER ASSEMBLY
2 357-9701	FILTER ELEMENT
3 247-4502	COMPRESSOR PUMP
4 432-2-1	FLYWHEEL - 20" OD
5 EG-9485	BELT GUARD
6 ALT230	ALTERNATOR RELAY 230V
TRN-460230	TRANSFORMER (460V UNIT)
TRN-575230	TRANSFORMER (575V UNIT)
7 MS-140-03	MAG STARTER 230-60-1
MS-340-43	MAG STARTER 200/230/460/575-60-3

8 MO-9320	MOTOR 230-60-1
MO-6507	MOTOR 200-60-3
MO-6535	MOTOR 230/460-60-3
MO-6514	MOTOR 575-60-3
9 PU-9193	MOTOR PULLEY
10 BT-9042	BELTS (1 PHASE)
BT-39	BELTS (3 PHASE)
11 SSS-9005UI20150	PRESSURE SWITCH
12 SSS-9005UI20150	PRESSURE SWITCH
13 GA-250	PRESSURE GAUGE
14 TIA-5200	SAFETY VALVE 200 PSI

15 CCV-9406	CHECK VALVE
16 VA-9411	BALL VALVE
17 TA-9507	TANK - 120 GALLON DUPLEX
18 VA-9715-1	CHECK VALVE
19 VA-9705	BALL VALVE
20 CT-9758	AFTERCOOLER

REV.	DATE	REVISION DESCRIPTION	ECN NO.
B	22.12.14	MO-9514 TO MO-6514	
C	01.04.16	CCV-9406 WAS CCV-9403, CT-9758 WAS CT-9739	16-07
D	30.09.16	VA-9411 WAS SS-2707	----
04	28.11.19	SSS-9005UI20150 WAS SSS-9003-115150	1130665
FA	26.09.24	MO-9320 WAS MO-9033	1523174

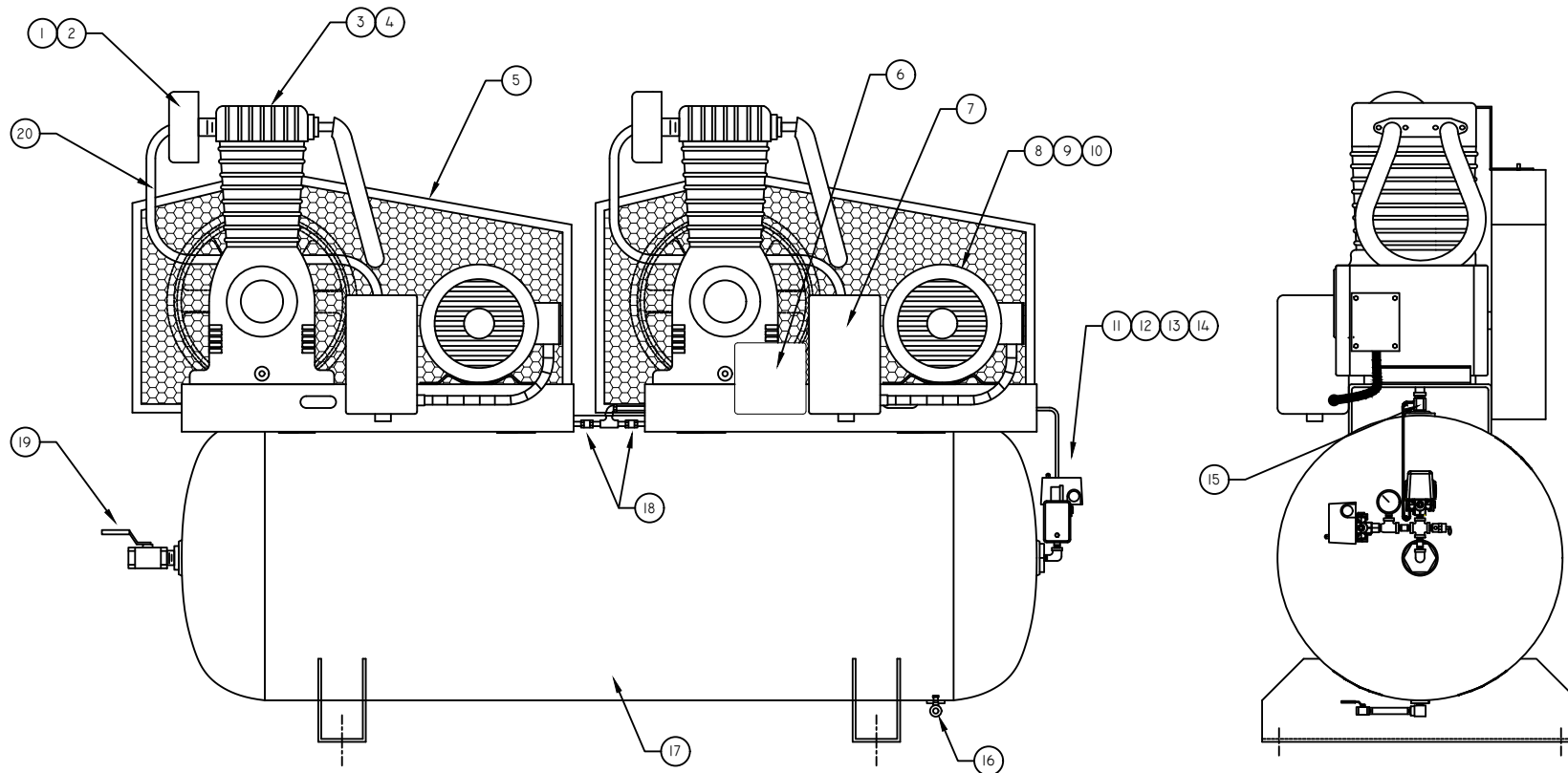

IMPORTANT NOTE: THIS PRINT IS THE CONFIDENTIAL PROPERTY OF GARDNER DENVER CANADA, CORP. IT IS NOT TO BE USED OR REPRODUCED IN ANY MANNER, NOR SUBMITTED TO OTHER PARTIES FOR EXAMINATION WITHOUT THE PRIOR APPROVAL OF GARDNER DENVER CANADA, CORP. GARDNER DENVER CANADA, CORP. IS CONTINUALLY TRYING TO IMPROVE ITS PRODUCTS, SPECIFICATIONS SUBJECT TO CHANGE WITHOUT NOTICE.

FRACTIONAL DIMENSIONS: $\pm 1/32$
 DECIMAL DIMENSION: $\pm .005$
 ANGLES: $\pm 1'$
 *UNLESS OTHERWISE SPECIFIED



NAME OF PROJECT				DESCRIPTION OF DRAWING	
7.5 HP DUPLEX UNIT C/W 247 PUMPS				COMPRESSOR OUTFIT	
DRAWN BY		CHECKED BY	DATE	SCALE	DRAWING NO.
ADAM SMITH			22DEC'14	N.T.S.	TAS-5562
					SHT NO
					REV
					FA