

REV.	DATE	REVISION DESCRIPTION	PCN NO.
C	24/09/09	PRESSURE SWITCH MANIFOLD RELOCATED	09-02B
D	09/02/11	MANIFOLD ORIENTATION	---
E	19/06/14	CAST INTERCOOLER, AIR OUTLET ORIENTATION	---

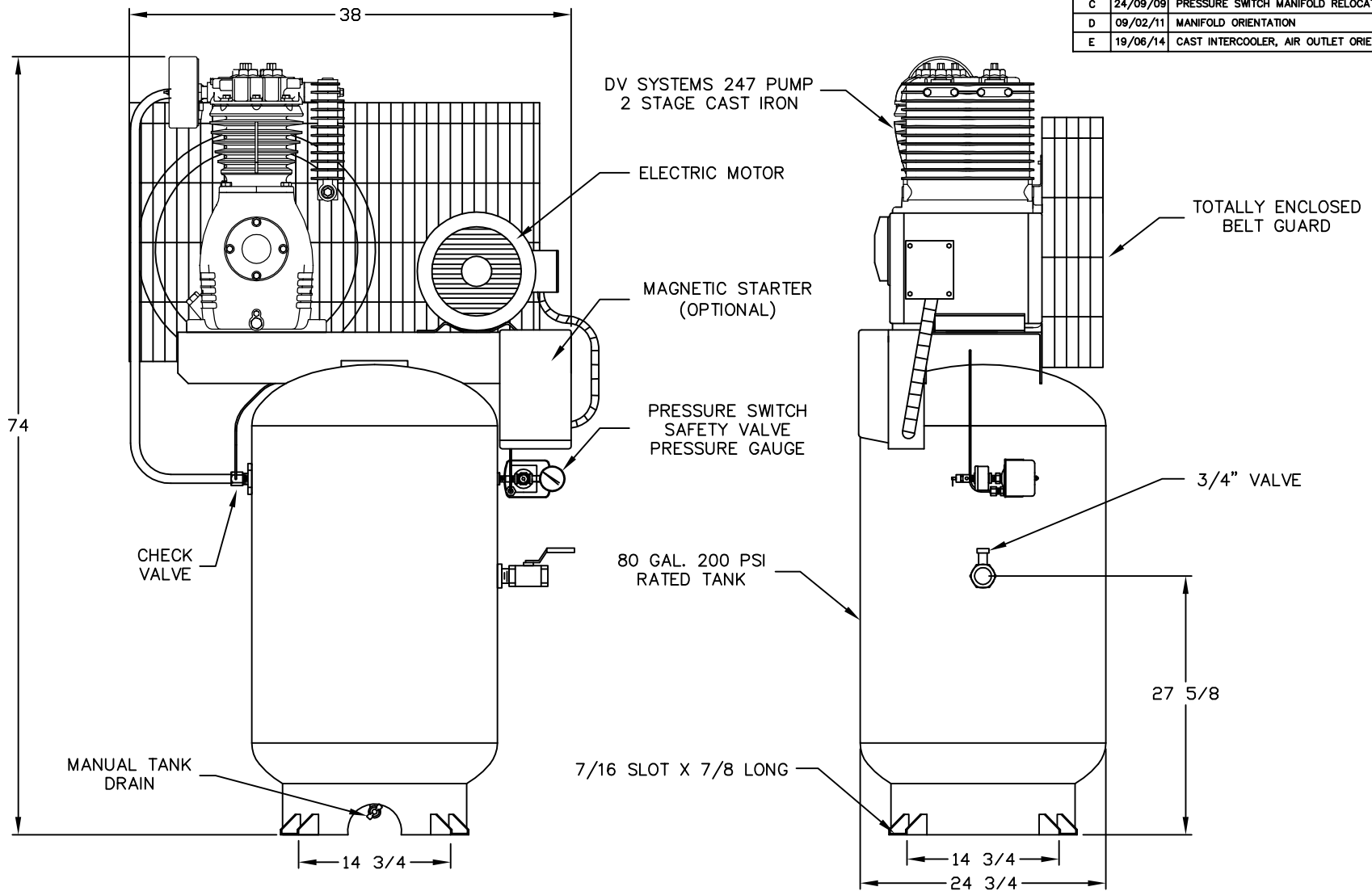

COMPRESSOR OUTFIT DATA				PRESSURE SETTING		RECEIVER CAPACITY		COMPRESSOR PUMP DATA				WEIGHT		ELECTRICAL					
MODEL	HP	DISP SCFM	DEL'Y SCFM	PSIG	KPA	GAL.	LITRS	TYPE	CYLD.	STAGE	RPM	LB.	KG.	VOLTAGE	230/1	200/3	230/3	460/3	575/3
TASV-5052	7.5	28.9	25.9	150	1034	80	302	247	2	2	800	700	317	F.L.A.	36	21.3	20	10	8

IMPORTANT NOTE: THIS PRINT IS THE CONFIDENTIAL PROPERTY OF DV SYSTEMS, INC. IT IS NOT TO BE USED OR REPRODUCED IN ANY MANNER, NOR SUBMITTED TO OTHER PARTIES FOR EXAMINATION WITHOUT THE PRIOR APPROVAL OF DV SYSTEMS, INC. DV SYSTEMS, INC. IS CONTINUALLY TRYING TO IMPROVE ITS PRODUCTS, SPECIFICATIONS SUBJECT TO CHANGE WITHOUT NOTICE.

FRACTIONAL DIMENSIONS: $\pm 1/32$
 DECIMAL DIMENSION: ± 0.005
 ANGLES: $\pm 1'$
 *UNLESS OTHERWISE SPECIFIED



NAME OF PROJECT				DESCRIPTION OF DRAWING			
7-1/2 HP SIMPLEX C/W 247 PUMP				COMPRESSOR OUTFIT			
DRAWN BY		CHECKED BY		DATE		SCALE	
I FILSOOFI				18 JAN. 99		N.T.S.	
DRAWING NO.				SHT NO/REV			
TASV-5052				E			

	PART NUMBER	DESCRIPTION
1	357-9401	FILTER ASSEMBLY
2	357-9701	FILTER ELEMENT
3	247-4502	COMPRESSOR PUMP
4	432-2-1	FLYWHEEL - 20" OD
5	EG-9495	BELT GUARD
6	MS-140-03	MAG STARTER 230-60-1
	MS-340-43	MAG STARTER 200/230-60-3
	MS-340-45	MAG STARTER 460-60-3
	MS-340-69	MAG STARTER 575-60-3
7	MO-9033	MOTOR 230-60-1
	MO-6507	MOTOR 200-60-3
	MO-6535	MOTOR 230/460-60-3
	MO-6514	MOTOR 575-60-3
8	PU-9193	MOTOR PULLEY
9	BT-9042	BELTS (1 PHASE)
	BT-39	BELTS (3 PHASE)
10	SSS-9003UII5150	PRESSURE SWITCH
11	GA-250	PRESSURE GAUGE
12	TIA-5200	SAFETY VALVE 200 PSI
13	VA-9705	BALL VALVE
14	VA-9411	DRAIN VALVE
15	TA-9496-3	TANK - 80 GAL VERT
16	CCV-9406	CHECK VALVE
17	CT-9753	AFTERCoolER TUBE

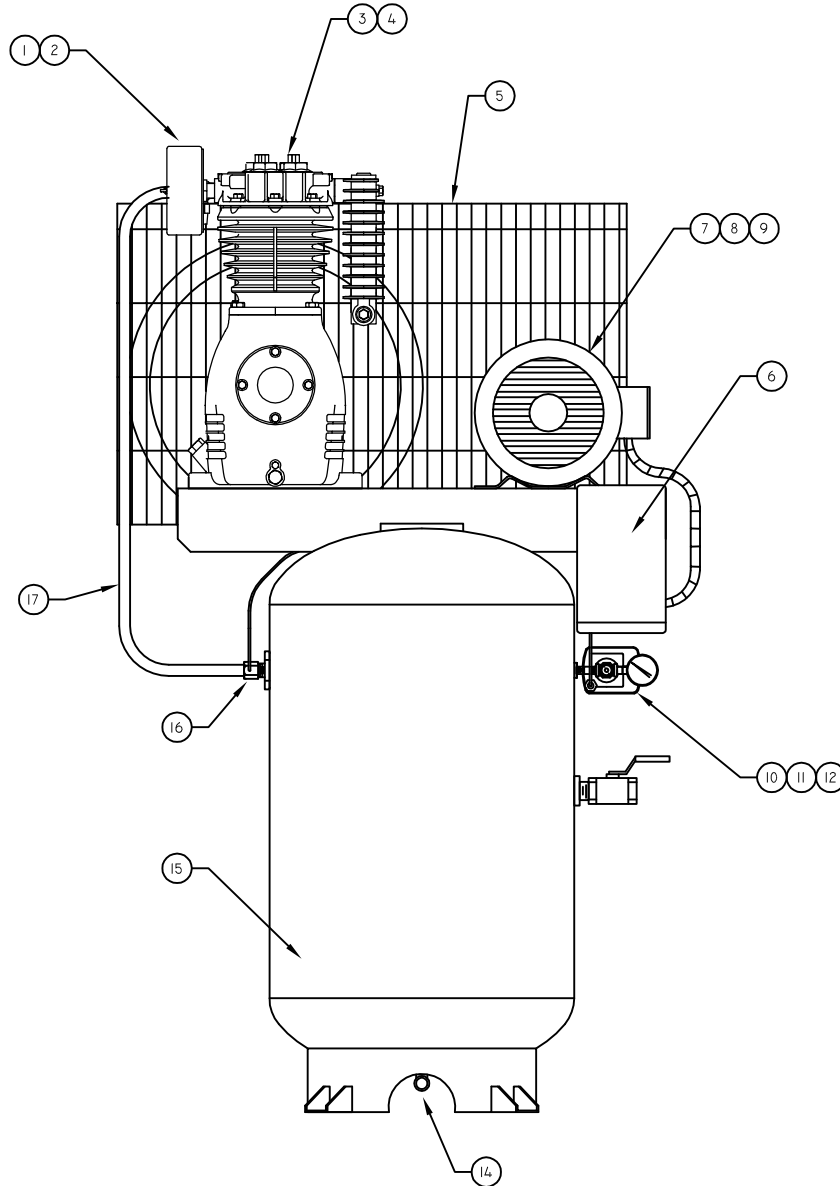

REV.	DATE	REVISION DESCRIPTION	PCN NO.
C	02.10.09	PRESSURE SWITCH MANIFOLD LOCATION	09-02B
D	09.02.11	MANIFOLD ORIENTATION	----
E	23.06.14	BELT GUARD, CAST INTERCOOLER	13-09

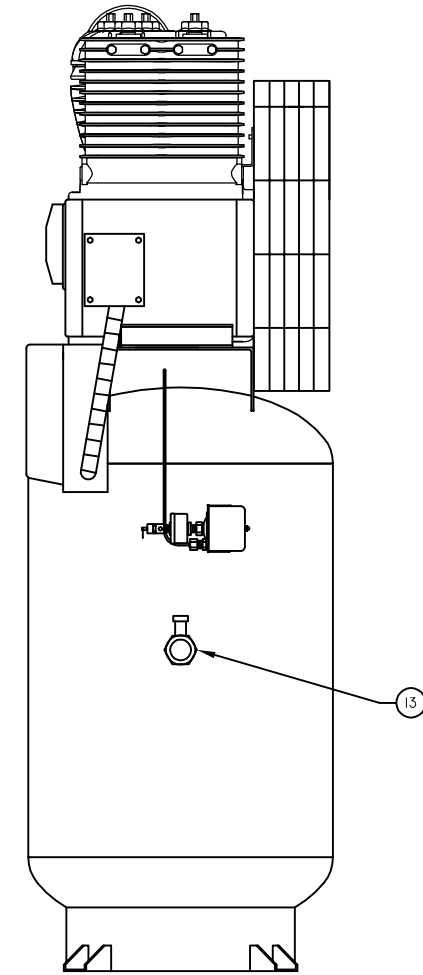

IMPORTANT NOTE: THIS PRINT IS THE CONFIDENTIAL PROPERTY OF DV SYSTEMS, INC. IT IS NOT TO BE USED OR REPRODUCED IN ANY MANNER, NOR SUBMITTED TO OTHER PARTIES FOR EXAMINATION WITHOUT THE PRIOR APPROVAL OF DV SYSTEMS, INC. DV SYSTEMS, INC. IS CONTINUALLY TRYING TO IMPROVE ITS PRODUCTS, SPECIFICATIONS SUBJECT TO CHANGE WITHOUT NOTICE.

FRACTIONAL DIMENSIONS: $\pm 1/32$
 DECIMAL DIMENSION: $\pm .005$
 ANGLES: $\pm 1'$
 *UNLESS OTHERWISE SPECIFIED



NAME OF PROJECT				DESCRIPTION OF DRAWING		
7.5 HP SIMPLEX UNIT C/W 247 PUMP				COMPRESSOR OUTFIT		
DRAWN BY		CHECKED BY	DATE	SCALE	DRAWING NO.	SHT NO/REV
IRAJ FILSOOFI			28 APR/00	N.T.S.	TASV-5052	E