

REV.	DATE	REVISION DESCRIPTION	ECN NO.
	MAR27'06	NEW	06-05
	AUG29'14	UPDATES	---
A	JUN29'18	ELECTRICAL UPDATED	---
01	DEC02'19	SSS-9005U120150 WAS SSS-9003-115150	1130665
FA	SEP27'24	TAS-5002 EFLA 230/1-31.0 WAS TAS-5002 EFLA 230/1-36.0	1523174

'247' SERIES TWO STAGE,
TWO CYLINDER PUMP

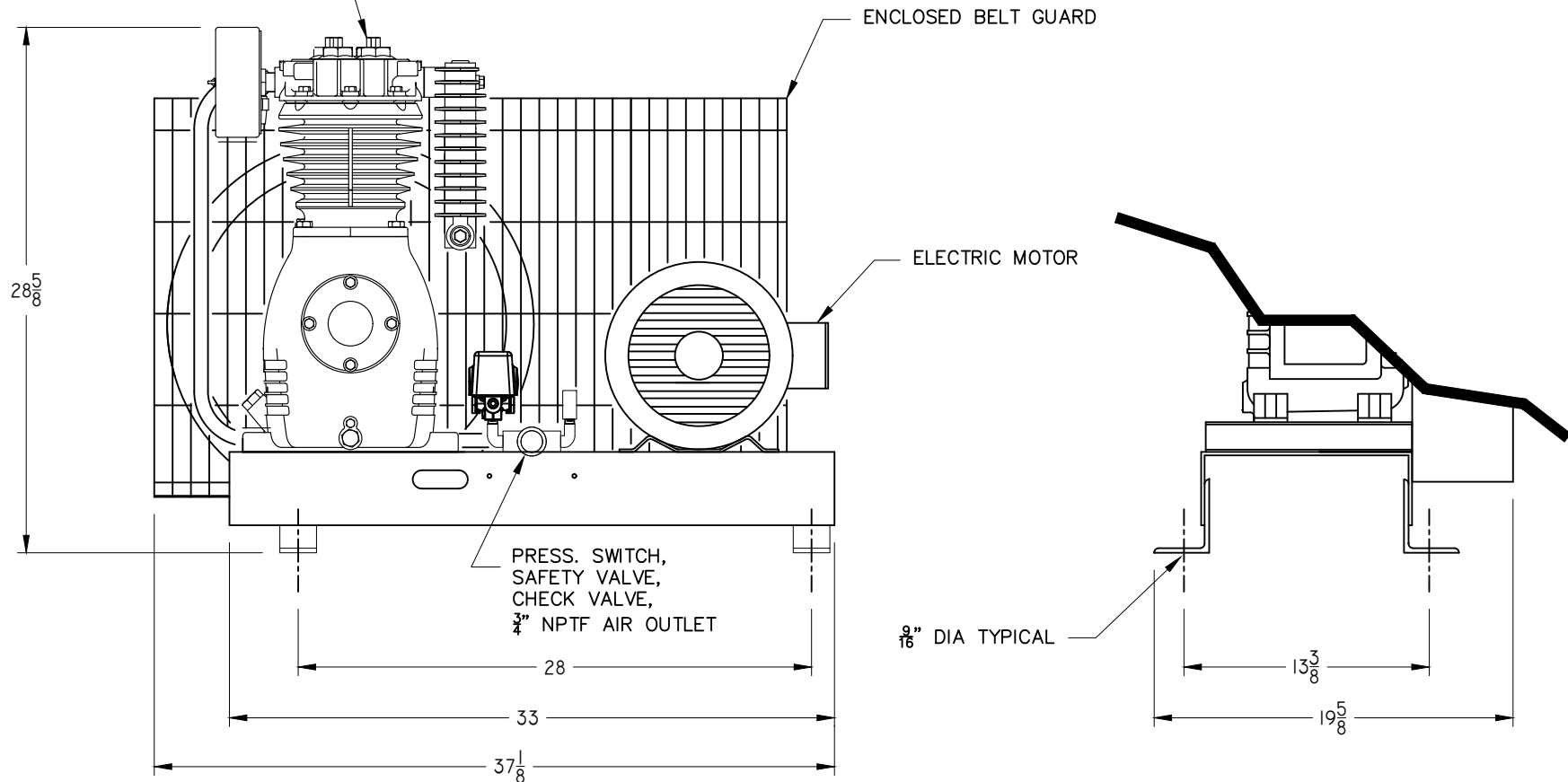

MODEL	HP	DISPLACEMENT		DELIVERY		PRESSURE SETTING	PUMP TYPE	DATA RPM	WEIGHT LB.	KG.	ELECTRICAL - VOLTAGE & F.L.A.				
		SCFM	L/S	SCFM	L/S						230/1	200/3	230/3	460/3	575/3
TAP-5002	5	23.4	11.2	19.1	9.1	150 PSIG 1035 KPA	247	635	433	197	23.0	15.3	13.2	6.6	5.3
TAS-5002	7.5	28.9	13.8	25.8	12.3			800	448	203	31.0	23.3	19.4	9.7	8.0

IMPORTANT NOTE: THIS PRINT IS THE CONFIDENTIAL PROPERTY OF GARDNER DENVER CANADA, CORP. IT IS NOT TO BE USED OR REPRODUCED IN ANY MANNER, NOR SUBMITTED TO OTHER PARTIES FOR EXAMINATION WITHOUT THE PRIOR APPROVAL OF GARDNER DENVER CANADA, CORP. GARDNER DENVER CANADA, CORP. IS CONTINUALLY TRYING TO IMPROVE ITS PRODUCTS, SPECIFICATIONS SUBJECT TO CHANGE WITHOUT NOTICE.

FRACTIONAL DIMENSIONS: $\pm 1/32$
DECIMAL DIMENSION: $\pm .005$
ANGLES: $\pm 1'$
*UNLESS OTHERWISE SPECIFIED



NAME OF PROJECT				DESCRIPTION OF DRAWING		
BASE MOUNTED PISTON COMPRESSOR				COMPRESSOR OUTFIT		
DRAWN BY		CHECKED BY		DATE	SCALE	DRAWING NO.
W.BLOM				MAR27'06	N.T.S.	TAP-TAS-5002
					SHT NO	REV.
						FA

REF	PART NO.	DESCRIPTION
1	357-9401	FILTER ASSEMBLY
2	357-9701	FILTER ELEMENT
3	247-4502	PUMP ASSY LESS CPR
4	432-2-1	FLYWHEEL-20" OD
5	EG-9485	BELT GUARD
6	MO-9320	MOTOR 230-1
	MO-6507	MOTOR 200-3
	MO-6535	MOTOR 230/460-3
	MO-6514	MOTOR 575-3
7	PU-9193	PULLEY
8	BT-9042	BELT (1 PHASE UNITS)
	BT-39	BELT (3 PHASE UNITS)
9	HCB-9449-2	BASE ASSY.
10	SSS-9005U120150	PRESSURE SWITCH
11	TIA-5200	SAFETY VALVE-200 PSI
12	ACC-9092	CHECK VALVE

REV.	DATE	REVISION DESCRIPTION	ECN NO.
01	DEC28'19	SSS-9005U120150 WAS SSS-9003U115150	1130665
FA	SEP26'24	MO-9320 WAS MO-9033	1523174

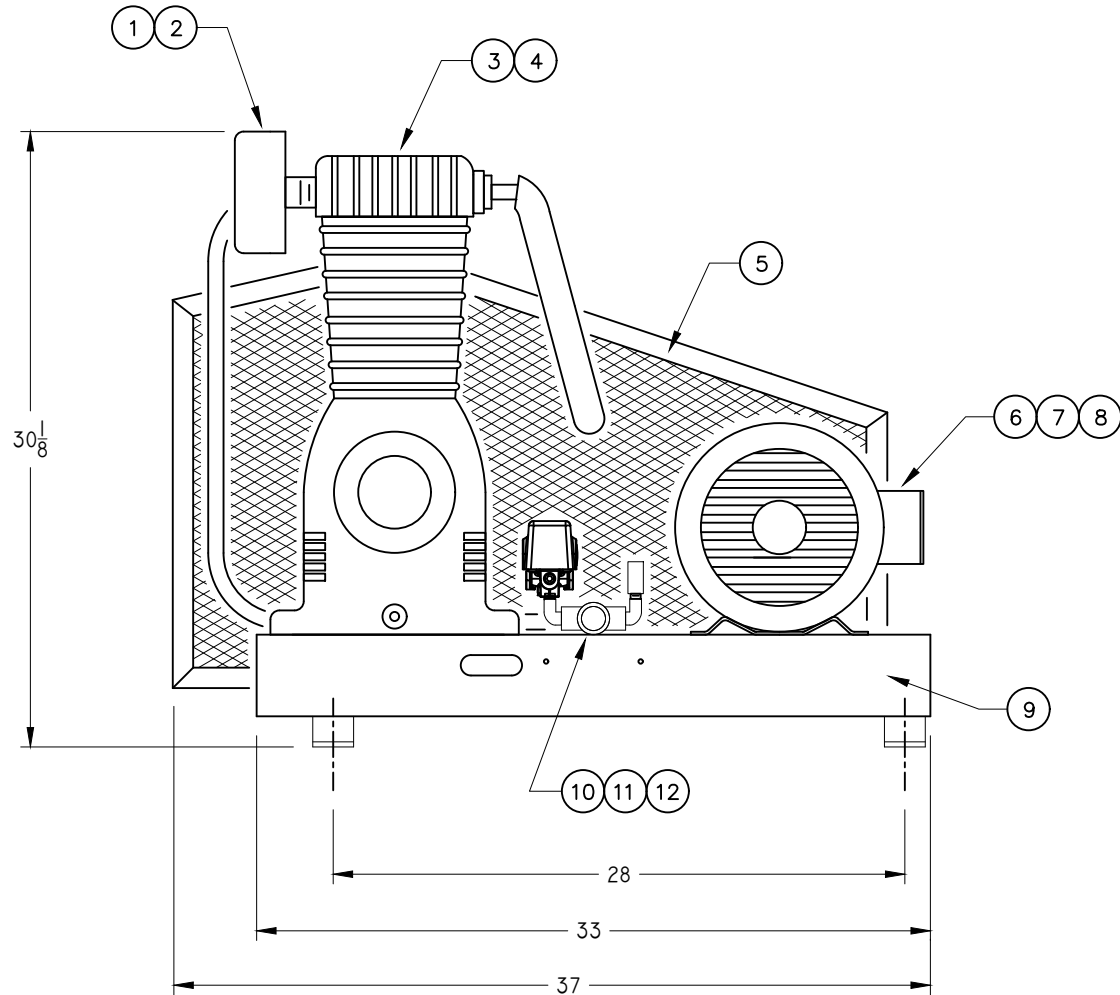

IMPORTANT NOTE: THIS PRINT IS THE CONFIDENTIAL PROPERTY OF GARDNER DENVER CANADA, CORP. IT IS NOT TO BE USED OR REPRODUCED IN ANY MANNER, NOR SUBMITTED TO OTHER PARTIES FOR EXAMINATION WITHOUT THE PRIOR APPROVAL OF GARDNER DENVER CANADA, CORP. GARDNER DENVER CANADA, CORP. IS CONTINUALLY TRYING TO IMPROVE ITS PRODUCTS, SPECIFICATIONS SUBJECT TO CHANGE WITHOUT NOTICE.

FRACTIONAL DIMENSIONS: ±1/32
 DECIMAL DIMENSION: ±.005
 ANGLES: ±1°
 *UNLESS OTHERWISE SPECIFIED



NAME OF PROJECT				DESCRIPTION OF DRAWING		
7-1/2 HP BASE MOUNTED C/W 247 SERIES PUMP				COMPRESSOR OUTFIT		
DRAWN BY	CHECKED BY	DATE	SCALE	DRAWING NO.	SHT NO	REV.
W.BLOM		MAR27'06	N.T.S.	TAS-5002		FA