

REV.	DATE	REVISION DESCRIPTION	ECN NO.
	5JULY'05	NEW	05-13
A	24SEP'09	PRESSURE SWITCH MANIFOLD RELOCATED	09-02B
B	08FEB'11	DWG. SPEC. UPDATE	----
C	21JUN'18	ELECTRICAL UPDATED	----
03	23DEC'18	SSS-9005U120150 WAS SSS-9003-115150	18-28
E	05OCT'20	DISPLACEMENT CFM REMOVED FROM CHART TABLE	1136291

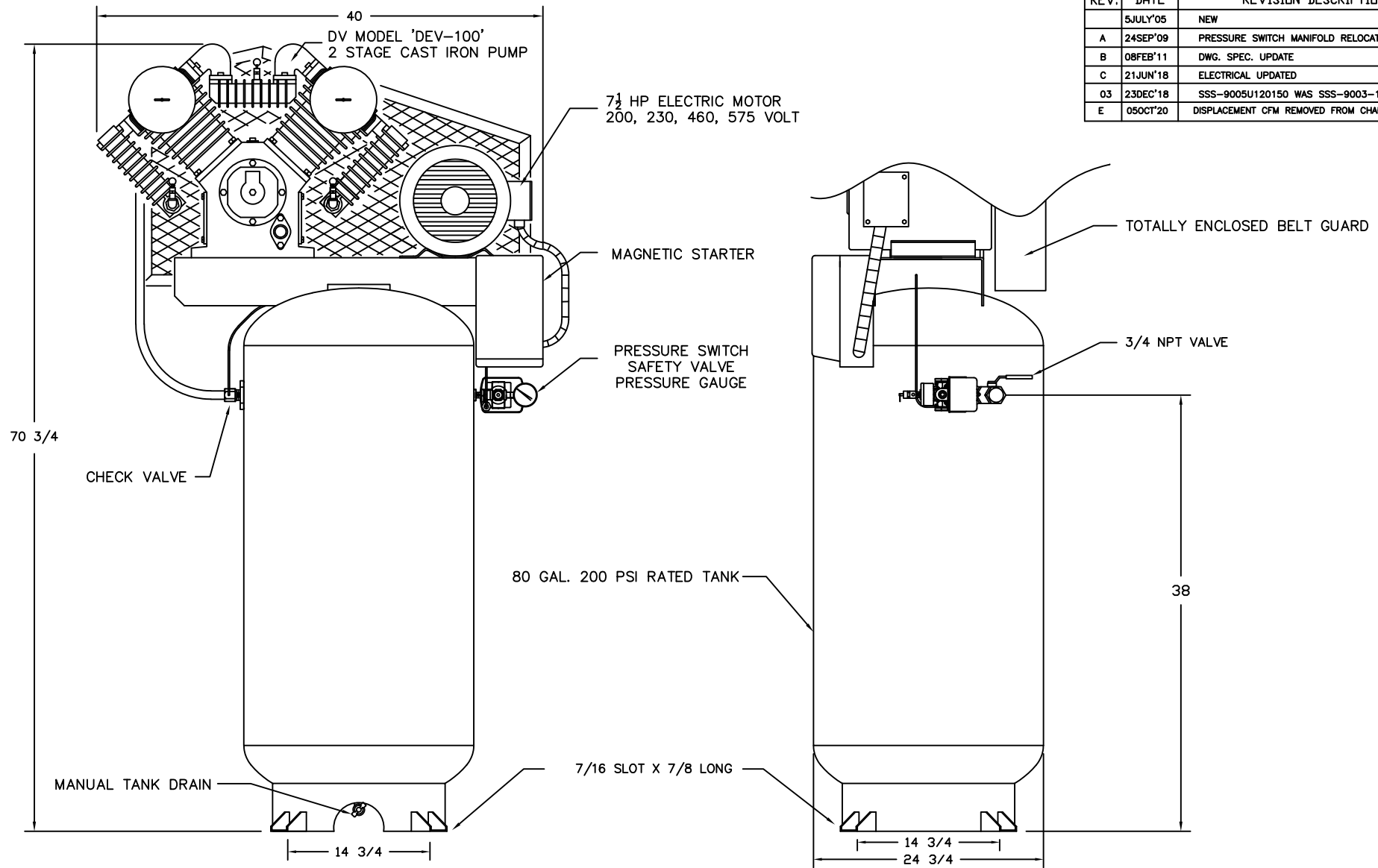

COMPRESSOR OUTFIT DATA			PRESSURE SETTING		RECEIVER CAPACITY		COMPRESSOR PUMP DATA				WEIGHT		ELECTRICAL					
MODEL	HP	DEL'Y SCFM	PSIG	KPA	GAL.	LITRS	TYPE	CYLD.	STAGE	RPM	LB.	KG.	VOLTAGE	230/1	200/3	230/3	460/3	575/3
IS7-10080	7.5	22.7	150	1035	80	302	DEV-100	4	2	570	720	327	FULL LOAD AMP	36	23.3	19.4	9.7	8

IMPORTANT NOTE: This print is the confidential property of GARDNER DENVER CANADA, CORP. It is not to be used or reproduced in any manner, nor submitted to other parties for examination without the prior approval of GARDNER DENVER CANADA, CORP. GARDNER DENVER CANADA, CORP. is continually trying to improve its products, specifications subject to change without notice.

FRACTIONAL DIMENSIONS: $\pm 1/32$
 DECIMAL DIMENSION: $\pm .005$
 ANGLES: $\pm 1'$
 *UNLESS OTHERWISE SPECIFIED



NAME OF PROJECT				DESCRIPTION OF DRAWING		
IS PISTON COMPRESSOR				COMPRESSOR OUTFIT		
DRAWN BY	CHECKED BY	DATE	SCALE	DRAWING NO.	SHT NO	REV
W.BLOM		5JULY'05	N.T.S.	IS7-10080		E

REV.	DATE	REVISION DESCRIPTION	PCN NO.
	09FEB'05	NEW	05-04
D	27APR'12	VA-9411 WAS SS-2707	12-10
E	01AUG'14	MO-9025 ADDED, WAS MO-6425	14-21
F	12OCT'18	EG-9495 ADDED, WAS EG-9491	13-09
		ADDED SSS-9005U120150 WAS SSS-9003U115150 SN =>092486	18-28
FA	26SEP'24	MO-9320 WAS MO-9033	1523174

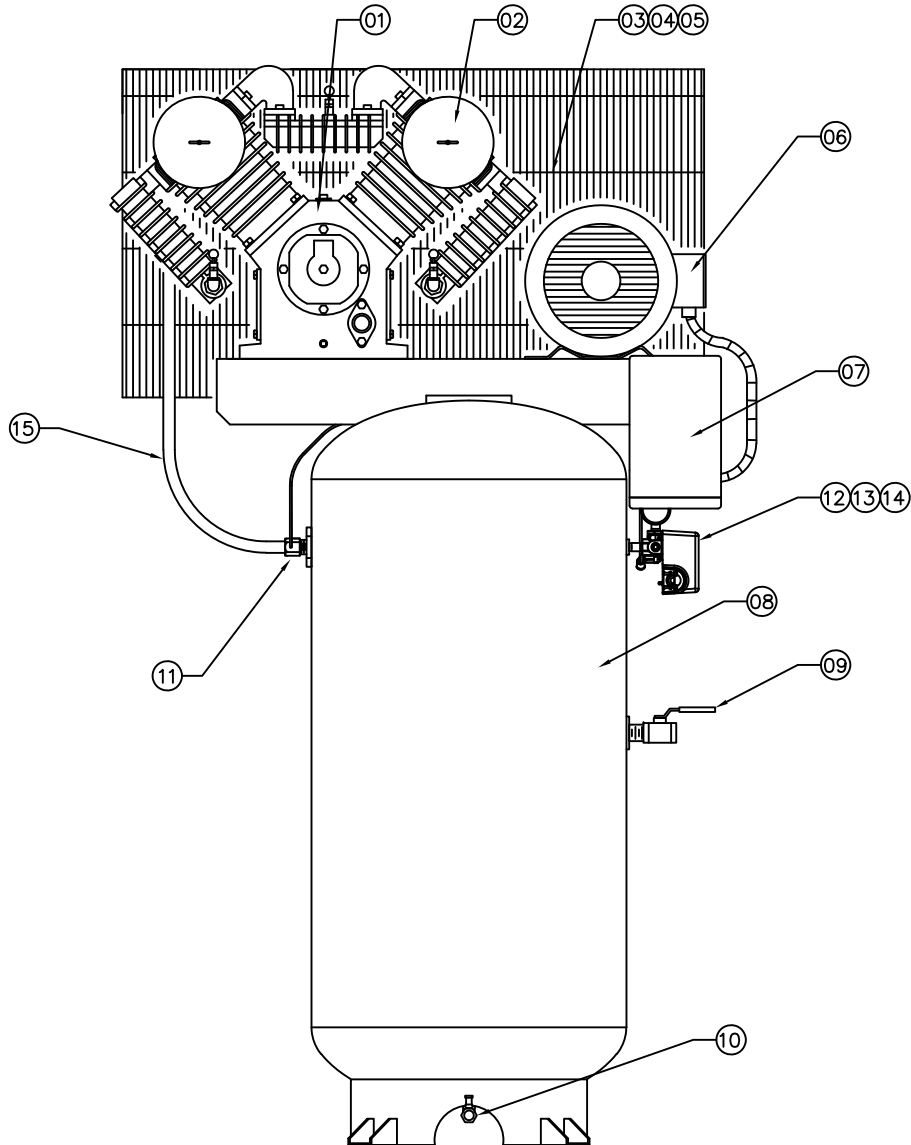

ITEM	PART NUMBER	QTY	DESCRIPTION
01	DEV-100	1	PUMP ASSEMBLY
02	PB-21176001	2	INTAKE FILTER ASSEMBLY
	PB-21177013	2	INTAKE FILTER ELEMENT
03	EG-9495	1	BELT GUARD ASSEMBLY
04	PU-9091	1	MOTOR PULLEY (6.35 OD, 1 ³ / ₈ " BORE, 2B)
05	BT-9041	2	DRIVE BELT (B74)
06	MO-9320	1	MOTOR 230-60-1
	MO-6507	1	MOTOR 200/208-60-3
	MO-6535	1	MOTOR 230-60-3
	MO-6535	1	MOTOR 460-60-3
	MO-6514	1	MOTOR 575-60-3
07	MS-140-03	1	STARTER 230-60-1
	MS-340-43	1	STARTER 200/208-60-3
	MS-340-43	1	STARTER 230-60-3
	MS-340-45	1	STARTER 460-60-3
	MS-340-69	1	STARTER 575-60-3
08	TA-9501	1	TANK - 80 GALLON VERT.
09	VA-9705	1	BALL VALVE
10	VA-9411	1	DRAIN VALVE
11	CCV-9406	1	CHECK VALVE
12	SSS-9005U120150	1	PRESSURE SWITCH
13	GA-250	1	PRESSURE GAUGE
14	TIA-5200	1	SAFETY VALVE 200 PSI
15	CT-9749	1	AFTERCOOLER TUBE

IMPORTANT NOTE: This print is the confidential property of DV SYSTEMS, INC. It is not to be used or reproduced in any manner, nor submitted to other parties for examination without the prior approval of DV SYSTEMS, INC. DV SYSTEMS, INC. is continually trying to improve its products, specifications subject to change without notice.

FRACTIONAL DIMENSIONS: ±1/32
 DECIMAL DIMENSION: ±.005
 ANGLES: ±1°
 *UNLESS OTHERWISE SPECIFIED



NAME OF PROJECT				DESCRIPTION OF DRAWING		
7.5 HP INDUSTRIAL STANDARD UNIT C/W 'DEV-100' PUMP				COMPRESSOR OUTFIT		
DRAWN BY	CHECKED BY	DATE	SCALE	DRAWING NO.	SHT NO	REV
W.BLOM		09FEB'05	N.T.S.	IS7-10080		FA