

REV	DATE	REVISION DESCRIPTION	ECN NO.
	7/06/10	NEW	05-04
B	3/29/17	TANK UPDATED	----
C	6/21/18	ELECTRICAL UPDATED	----
D	11/27/18	ELECTRICAL UPDATED	----
04	12/23/19	SSS-9005U120150 WAS SSS-9003-115150	18-28
F	05OCT'20	DISPLACEMENT CFM REMOVED FROM CHART TABLE	1136291

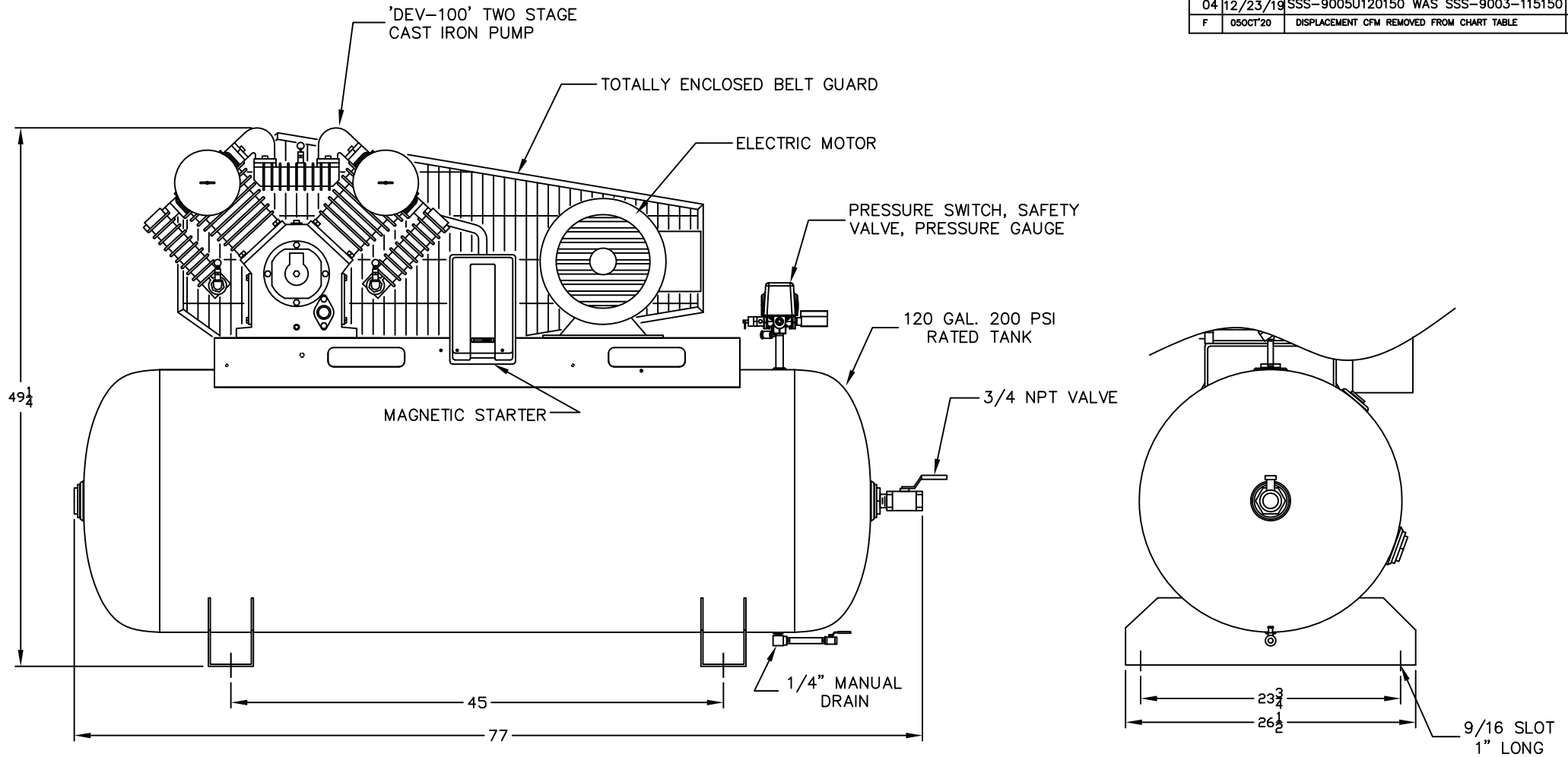

COMPRESSOR OUTFIT DATA			PRESSURE SETTING		RECEIVER CAPACITY		COMPRESSOR PUMP DATA				WEIGHT		ELECTRICAL					
MODEL	HP	DEL'Y SCFM	PSIG	KPA	GAL.	LITRS	TYPE	CYLD.	STAGE	RPM	LB.	KG.	VOLTAGE	230/1	200/3	230/3	460/3	575/3
IS7-100120	7.5	22.7	150	1035	120	454	DEV-100	4	2	570	920	417	F.L.A.	36	23.3	19.4	9.7	8

IMPORTANT NOTE: THIS PRINT IS THE CONFIDENTIAL PROPERTY OF GARDNER DENVER CANADA, CORP. IT IS NOT TO BE USED OR REPRODUCED IN ANY MANNER, NOR SUBMITTED TO OTHER PARTIES FOR EXAMINATION WITHOUT THE PRIOR APPROVAL OF GARDNER DENVER CANADA, CORP. GARDNER DENVER CANADA, CORP. IS CONTINUALLY TRYING TO IMPROVE ITS PRODUCTS, SPECIFICATIONS SUBJECT TO CHANGE WITHOUT NOTICE.



NAME OF PROJECT				DESCRIPTION OF DRAWING			
IS PISTON COMPRESSOR				COMPRESSOR OUTFIT			
DRAWN BY		CHECKED BY		DATE		SCALE	
LT				7/06/10		N.T.S.	
DRAWING NO.				SHT NO/REV			
IS7-100120							
				F			

REV.	DATE	REVISION DESCRIPTION	PCN NO.
B	05/17/11	BELT TO BT-9046	11-10
C		VA-9411 WAS SS-2707	12-10
D	04/04/17	TANK DRAWING UPDATED	----
E	09/28/18	ADDED SSS-9005U120150 WAS SSS-9003U115150 SN =>092486	18-28
F	03/30/22	CORRECTED STARTER P/N MS-140-03 WAS MS-140-43	----
FA	09/26/24	MO-9320 WAS MO-9033	1523174

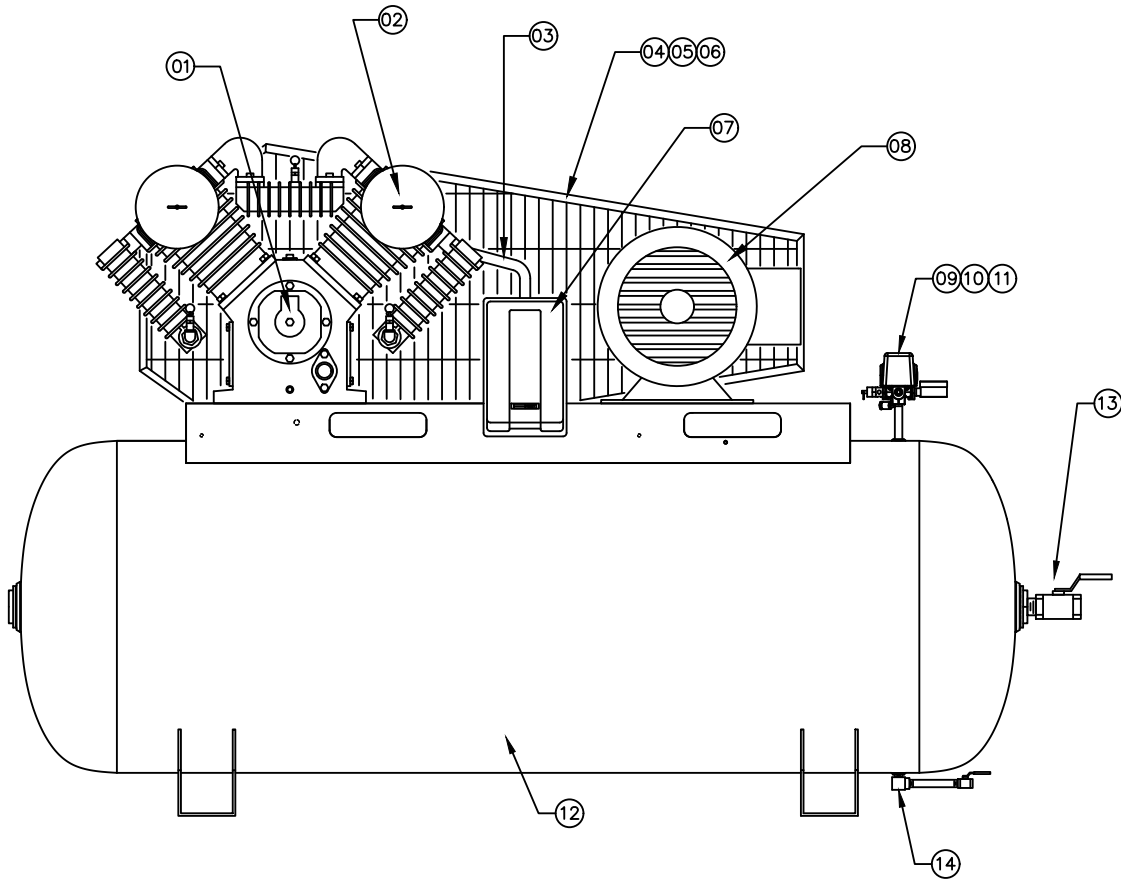

ITEM	PART NUMBER	QTY	DESCRIPTION
01	DEV-100	1	PUMP ASSEMBLY
02	PB-21176001	2	INTAKE FILTER ASSEMBLY
	PB-21177013	2	INTAKE FILTER ELEMENT
03	CT-9748	1	AFTERCOOLER TUBE
04	EG-9492	1	BELT GUARD ASSEMBLY
05	PU-9091	1	MOTOR PULLEY (6.35 OD, 1 $\frac{3}{8}$ " BORE, 2B)
06	BT-9046	2	DRIVE BELT (B93)
07	MS-140-03	1	STARTER 230-60-1
	MS-340-43	1	STARTER 200/208-60-3
	MS-340-43	1	STARTER 230-60-3
	MS-340-45	1	STARTER 460-60-3
	MS-340-69	1	STARTER 575-60-3
08	MO-9320	1	MOTOR 230-60-1
	MO-6507	1	MOTOR 200/208-60-3
	MO-6535	1	MOTOR 230-60-3
	MO-6535	1	MOTOR 460-60-3
	MO-6514	1	MOTOR 575-60-3
09	SSS-9005U120150	1	PRESSURE SWITCH
10	GA-250	1	PRESSURE GAUGE
11	TIA-5200	1	SAFETY VALVE 200 PSI
12	TA-9463-1	1	TANK - 120 GAL. HORIZ.
13	VA-9705	1	BALL VALVE
14	VA-9411	1	DRAIN VALVE
15	CCV-9408	1	CHECK VALVE (NOT SHOWN)

IMPORTANT NOTE: THIS PRINT IS THE CONFIDENTIAL PROPERTY OF DV SYSTEMS, INC. IT IS NOT TO BE USED OR REPRODUCED IN ANY MANNER, NOR SUBMITTED TO OTHER PARTIES FOR EXAMINATION WITHOUT THE PRIOR APPROVAL OF DV SYSTEMS, INC. DV SYSTEMS, INC. IS CONTINUALLY TRYING TO IMPROVE ITS PRODUCTS, SPECIFICATIONS SUBJECT TO CHANGE WITHOUT NOTICE.



NAME OF PROJECT				DESCRIPTION OF DRAWING	
IS PISTON COMPRESSOR				7.5 HP COMPRESSOR OUTFIT	
DRAWN BY		CHECKED BY	DATE	SCALE	DRAWING NO.
LT			07/06/10	N.T.S.	IS7-100120
					SHT NO/REV
					FA